

# ETT 412

## Touch Operating Panel

### Technical Manual

**Publisher: SIGMATEK GmbH & Co KG**  
**A-5112 Lamprechtshausen**  
**Tel.: +43/6274/4321**  
**Fax: +43/6274/4321-18**  
**Email: office@sigmatek.at**  
**WWW.SIGMATEK-AUTOMATION.COM**

Copyright © 2019  
SIGMATEK GmbH & Co KG

### **Translation from German**

All rights reserved. No part of this work may be reproduced, edited using an electronic system, duplicated or distributed in any form (print, photocopy, microfilm or in any other process) without express permission.

We reserve the right to make changes in the content without notice. SIGMATEK GmbH & Co KG is not responsible for technical or printing errors in this handbook and assumes no responsibility for damages that occur through its use.

## Touch Operating Panel

## ETT 412

The ETT 412 is used to visualize automated processes. Process diagnostics as well as operating and monitoring automated procedures are simplified using this control.

A projected capacitive touch screen serves as the input medium for process data and parameters. The output is shown on a 4.3" TFT color display.

With the LSE mask editor, graphics can be created on the PC, then stored and displayed on the terminal. Data is exchanged with the CPU via the CAN bus.

The display is constructed with a black anodized aluminum front.

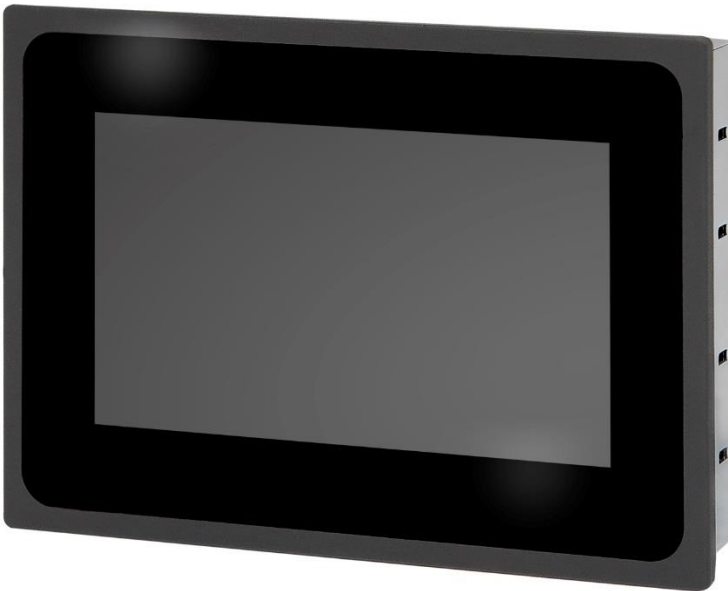

# Contents

<b>1</b>	<b>Introduction</b> .....	<b>4</b>
1.1	Target Group/Purpose of this Manual .....	4
1.2	Important Reference Documentation .....	4
1.3	Contents of Delivery .....	4
<b>2</b>	<b>Basic Safety Guidelines</b> .....	<b>5</b>
2.1	Symbols Used .....	5
2.2	Disclaimer .....	6
2.3	General Safety Guidelines .....	7
2.5	Guidelines.....	8
2.5.1	EU Conformity Declaration .....	8
<b>3</b>	<b>Technical Data</b> .....	<b>9</b>
3.1	Performance Data .....	9
3.2	Electrical Requirements.....	9
3.3	Controller.....	9
3.4	Display .....	9
3.5	Environmental Conditions .....	10
3.6	Miscellaneous .....	10
<b>4</b>	<b>Mechanical Dimensions</b> .....	<b>11</b>
<b>5</b>	<b>Connector Layout</b> .....	<b>12</b>
5.1	X1: CAN bus 5-pin Phoenix RM 3.5.....	12
5.2	X2: Supply (4-pin Phoenix RM 3.5) .....	12

---

5.3	Protective Earth Connection .....	13
5.4	Applicable Connectors.....	14
<b>6</b>	<b>Mounting Instructions.....</b>	<b>15</b>
6.1	Vertical Mounting Position .....	16
<b>7</b>	<b>CAN Bus Protocol .....</b>	<b>16</b>
<b>8</b>	<b>CAN Bus Setup.....</b>	<b>16</b>
8.1	CAN Bus Station Number .....	16
8.2	CAN Bus Data Transfer Rate .....	17
<b>9</b>	<b>CAN Bus Termination .....</b>	<b>18</b>
<b>10</b>	<b>Cleaning the Touch Screen .....</b>	<b>19</b>
<b>11</b>	<b>Transport/Storage .....</b>	<b>20</b>
<b>12</b>	<b>Assembly/Installation .....</b>	<b>21</b>
12.1	Check List.....	21
12.1.1	Check Contents of Delivery.....	21
12.2	Maintenance .....	21
12.3	Repair.....	21
<b>13</b>	<b>Disposal .....</b>	<b>22</b>

## 1 Introduction

### 1.1 Target Group/Purpose of this Manual

This manual contains all information required for operating the ETT 412-K.

This manual is intended for:

- Project planners
- Technicians
- Configurators/commissioning engineers
- Machine operators
- Maintenance/test technicians

General knowledge of automation technology is required.

Further help and training information, as well as the appropriate accessories can be found on our website [www.sigmatek-automation.com](http://www.sigmatek-automation.com)

Our support team is happily available to answer your questions.  
For our support hotline and business hours, please visit our website.

### 1.2 Important Reference Documentation

- HW IP Address Setting documentation

This document can be downloaded from our website or obtained through Support.

### 1.3 Contents of Delivery

1x ETT 412

1x opposing connector

This document can be downloaded from our website.  
Additional documents may be included with delivery.

## 2 Basic Safety Guidelines

### 2.1 Symbols Used

The following symbols are used in the operator documentation for warning and danger messages, as well as informational notes:

#### DANGER



Identifies an immediate danger with high risk, which **will** lead to immediate death or serious injury if not avoided.

Identifie un danger immédiat avec un risque élevé, entraînant le décès immédiat ou des blessures graves s'il n'est pas évité..

#### WARNING



Identifies a possible danger with a mid-level risk, which **can** lead to death or (serious) injury if not avoided.

Indique un danger possible d'un risque moyen de décès ou de (graves) blessures si les consignes de sécurité ne sont pas respectées

#### CAUTION



Identifies a low risk danger, which can lead to injury or property damage if not avoided.

Indique un danger avec un niveau de risque faible des blessures légères ou des dommages matériels si les consignes de sécurité ne sont pas respectées.



Provides user tips, informs of special features and identifies especially important information in the text.

Fournit des conseils d'utilisation, informe sur les fonctions particulières et souligne les informations particulièrement importantes dans le texte.

## 2.2 Disclaimer



The contents of this document were prepared with the greatest care. However, deviations cannot be ruled out. This document is regularly checked and required corrections are included in the subsequent versions. The machine manufacturer is responsible for the proper assembly, as well as device configuration. The machine operator is responsible for safe handling, as well as proper operation.

The current document can be found on our website. If necessary, contact our support.

Subject to technical changes, which improve the performance of the devices. The following documentation is purely a product description. It does not serve to guarantee properties under the warranty.

Please thoroughly read the corresponding data sheets, operating instructions and this system handbook before handling a product.

**SIGMATEK GmbH & Co KG is not liable for damages caused through, non-compliance with these instructions or applicable regulations.**

The general and special safety instructions described in the following sections, as well as technical regulations, must therefore be observed.



## 2.3 General Safety Guidelines



Observe all on-site rules and regulations for accident prevention and occupational safety.



According to EU guidelines, the operating instructions are a component of a product.

This manual must therefore be accessible in the vicinity of the machine since it contains important instructions.

This technical documentation should be included in the sale, rental or transfer of the product.

Maintain this manual in readable condition and keep it accessible for reference.

Operate the unit with devices and accessories approved by SIGMATEK only.

### CAUTION



In addition, the Safety Guidelines in the other sections of these instructions must be observed. These instructions are visually emphasized by symbols.

The module complies with EN 61131-2.

In combination with a machine, the machine builder must comply with EN 60204-1 standards.

For your own safety and that of others, compliance with the environmental conditions is essential.

To perform maintenance or repairs, disconnect the system from the power supply.

En outre, les consignes de sécurité mentionnées dans d'autres sections de ce manuel doivent être respectées. Ces directives sont indiquées avec les symboles graphiques.

Le module est conforme à la norme EN 61131-2.

En combinaison avec une machine, le constructeur de la machine doit respecter la norme EN 60204-1.

L'armoire de commande doit être raccordée correctement à la terre.

Pour l'entretien et les réparations, débranchez le système de l'alimentation.

## 2.5 Guidelines

The panel was constructed in compliance with European Union guidelines.

### 2.5.1 EU Conformity Declaration



---

#### CE Declaration of Conformity

The ETT 412 conforms to the following European guidelines:

- 2014/35/EU Low-voltage guideline
  - 2014/30/EU “Electromagnetic Compatibility” (EMC guideline)
  - 2011/65/EU “Restricted use of certain hazardous substances in electrical and electronic equipment” (RoHS Guideline)
-

## 3 Technical Data

### 3.1 Performance Data

Interfaces	1x CAN bus Data rate max. 1 Mbit/s
------------	---------------------------------------

### 3.2 Electrical Requirements

Supply voltage	typically +24 V (+18-30 V DC)	
Current consumption at 24 V DC	typically 75 mA	maximum 130 mA
Inrush current	typically 0.8 A for 10 ms	maximum 1.2 A for 20 ms

### 3.3 Controller

Controller	Cortex M3
Internal data memory for visualization (SDRAM)	8 Mbytes
Internal data memory for visualization (Flash)	8 Mbytes

### 3.4 Display

Type	4.3" TFT LCD color display
Resolution	480 x 272
Pixel size	0.198 x 0.198 mm
Number of pixels	480*3 (RGB) x 272 pixels
Active surface	95.04 x 53.86 mm
Color depth	24 bits
Backlighting	10x LED, white, adjustable
Contrast	600:1
Touch	projective capacitive
Brightness	typically 400 cd/m <sup>2</sup>
Visible field	left, right 80, above 70° and below 60°

### 3.5 Environmental Conditions

Storage temperature	-10 ... +70 °C	
Environmental temperature	0 ... +55 °C	
Humidity	10-90 %, non-condensing	
Installation altitude above sea level	0-2000 m without derating, > 2000 m with derating of the maximum environment temperature by 0.5 °C per 100 m	
Operating conditions	pollution degree 2 indoor use	
EMC resistance	in accordance with EN 61000-6-2 (industrial area)	
EMC noise generation	in accordance with EN 61000-6-4 (industrial area)	
Vibration resistance	EN 60068-2-6	3.5 mm from 5-8.4 Hz 1 g from 8.4-150 Hz
Shock resistance	EN 60068-2-27	15 g
Protection type	EN 60529	front: IP54 Cover IP20

### 3.6 Miscellaneous

Article number	01-230-412
Hardware version	1.x
Standard	CE

## 4 Mechanical Dimensions

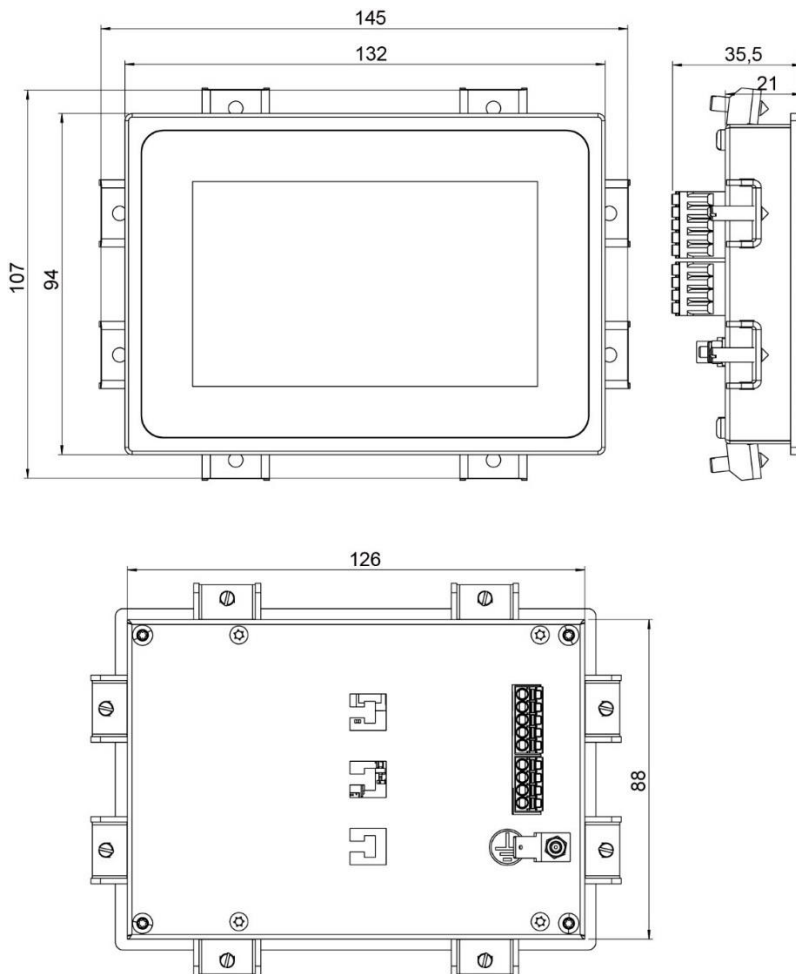

Operating unit dimensions	132 x 94 x 35.5 mm (W x H x D) with opposing connector 145.0 x 107.0 x 35.5 mm (W x H x D) with opposing connector and mounting brackets
Control cabinet cutout	127 x 89 (W x H) (+/- 0.4 mm)
Material	front: 0.7 mm glass (touchscreen) in black anodized 3 mm aluminum frame Cover: 0.8 mm chromed sheet steel
Weight	0.3 kg

## 5 Connector Layout

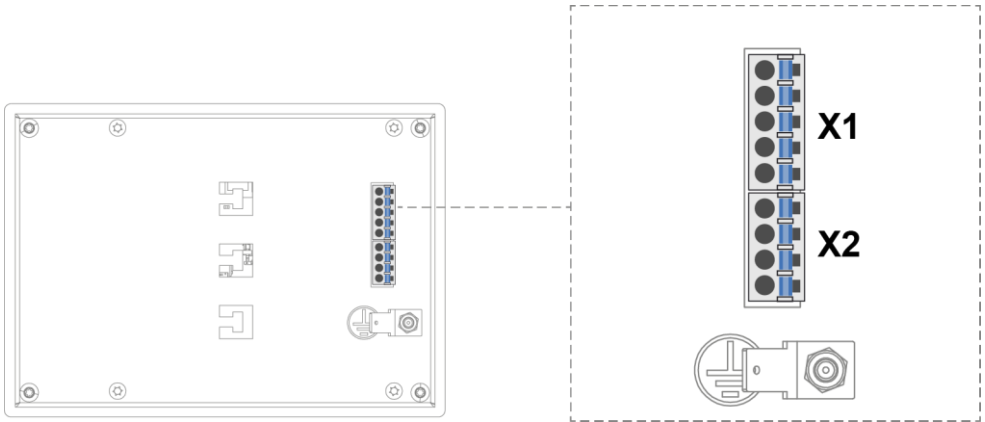

### 5.1 X1: CAN bus 5-pin Phoenix RM 3.5



Pin	Signal	Function
1	CAN A	CAN LOW IN
2	CAN B	CAN HIGH IN
3	CAN A	CAN LOW OUT
4	CAN B	CAN HIGH OUT
5	GND	GND

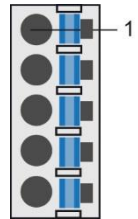

### 5.2 X2: Supply (4-pin Phoenix RM 3.5)

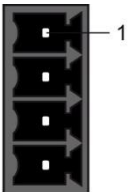

Pin	Signal	Function
1	+24 V	Supply voltage
2	+24 V	Supply voltage
3	GND	GND
4	GND	GND

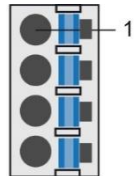

### 5.3 Protective Earth Connection

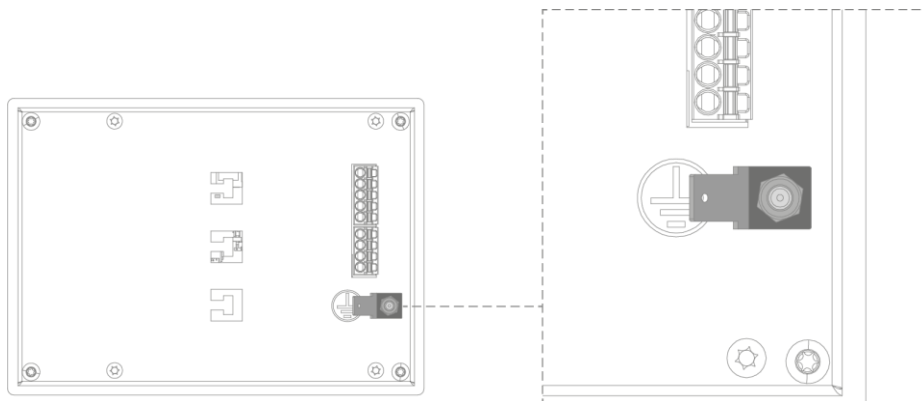

The terminal must be grounded to protective earth via the M3 threaded bolts and the blade terminal, as well as to the control cabinet over a broad surface via the mount. It is important to establish a low-Ohm connection to ground to ensure error-free function. The ground connection must be made with the maximum cross section and largest (electrical) surface possible. The cable length of the ground connection must also be kept as short as possible.

## 5.4 Applicable Connectors

### Connectors:

**X1, X2:** Connectors with spring terminals (included in delivery)

### Connections

Stripping length/sleeve length:	10 mm
Mating direction:	parallel to the conductor axis or circuit board
Conductor cross section rigid:	0.2-1.5 mm <sup>2</sup>
Conductor cross section flexible:	0.2-1.5 mm <sup>2</sup>
conductor cross section strands ultrasonically compacted:	0.2-1.5 mm <sup>2</sup>
Conductor cross section AWG/kcmil:	24-16
Conductor cross section flexible with ferrule:	0.25-1.5 mm <sup>2</sup>
Conductor cross section flexible with ferrule and plastic sleeve:	0.25-0.75 mm <sup>2</sup> (reason for reduction d2 of the ferrule)

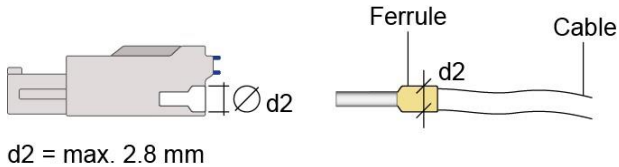



## 6 Mounting Instructions

The build-in terminal is provided for mounting in a control cabinet wall. For mounting in the control cabinet wall, 8 angle clamps with threaded pins are provided. The front is therewith pressed against the outer control cabinet wall. The brackets are affixed using a flat head screwdriver with 0.2 Nm and therewith guarantee the necessary IP protection level for the front.

The modules must be mounted vertically with sufficient clearance to nearby components and/or the control cabinet back wall. This is necessary for optimal cooling and air circulation, so that proper function up to the maximum operating temperature is ensured.

### CAUTION



The terminal must be grounded to protective earth via the M3 threaded bolts and the blade terminal, as well as to the control cabinet over a broad surface via the mount.

La borne doit être reliée à la terre par l'intermédiaire des boulons filetés M3 et de la borne à lame, ainsi qu'à l'armoire électrique sur une large surface via le support.

## 6.1 Vertical Mounting Position

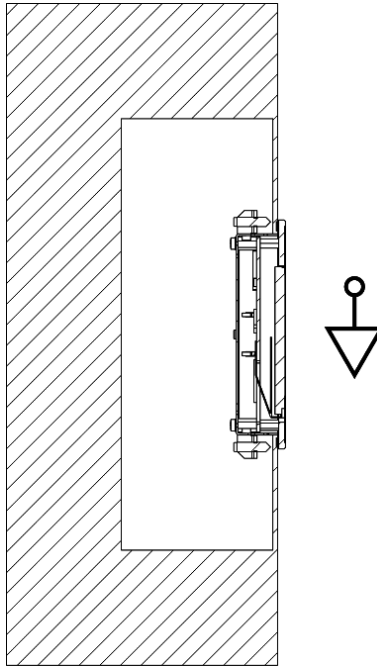

## 7 CAN Bus Protocol

Display communication CAN object number:

CAN bus object for receiving data:  $0x020 + \text{CAN bus station (0x00 - 0x1F)}$

CAN bus object for sending data:  $0x040 + \text{CAN bus station (0x00 - 0x1F)}$

## 8 CAN Bus Setup

This section explains how to configure a CAN bus correctly. The following parameters must first be set: Station number and data transfer rate.

During start up the parameters can be set on the setup screen of the terminal.

### 8.1 CAN Bus Station Number

Each CAN bus station is assigned its own station number. With this station number, data can be exchanged with other stations connected to the bus. Up to 31 stations can be installed in a CAN bus system. In a CAN bus system however, each station number can only be assigned once!

## 8.2 CAN Bus Data Transfer Rate

Various data transfer rates (baud rates) can be set on the CAN bus. The longer the bus line is, the lower the data transfer rate that must be selected.

Value	Baud rate	maximum length
1	500 kbits/s	80 m
2	250 kbits/s	160 m
3	125 kbits/s	320 m
4	100 kbits/s	400 m
5	50 kbits/s	800 m
6	20 kbits/s	1200 m
7	1 Mbit/s	30 m

These values apply to the following cable: 120  $\Omega$ , Twisted Pair.

## 9 CAN Bus Termination

In a CAN bus system, both end modules must be terminated. This is necessary to avoid transmission errors caused by reflections in the line. For the CAN bus a shielded connector cable must be used. The cable shielding must have a low-Ohm connection to the ground.

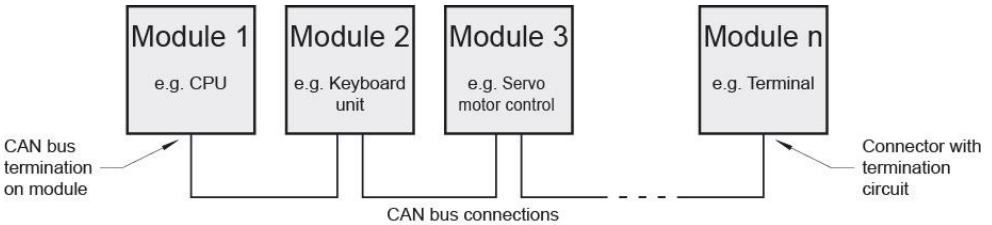

The line termination is provided by a 120  $\Omega$  resistor on the opposing connector between PIN 3 and PIN 4.

## 10 Cleaning the Touch Screen

### WARNING



Before cleaning the touch screen, the HGW must be turned off in order to prevent triggering functions or commands unintentionally!

Avant de nettoyer l'écran tactile, le HGW doit être éteint afin d'éviter tout déclenchement involontaire de fonctions ou de commandes!

The touch screen can only be cleaned with a soft, damp cloth. To dampen the cloth, a mild cleaning solution such as antistatic foam cleaner is recommended. To avoid fluids/cleaning solutions from getting into the housing, the device must not be sprayed directly. To clean, no corrosive cleaning solutions, chemicals, abrasive cleansers or hard objects that can scratch or damage the touch screen may be used. The use of steam jets or compressed air is prohibited.

### DANGER



If the device is contaminated with toxic or corrosive chemicals, it must be carefully cleaned as quickly as possible to prevent personal injury and machine damage!

Si l'appareil est contaminé par des produits chimiques toxiques ou corrosifs, il doit être nettoyé avec soin le plus rapidement possible afin d'éviter des dommages corporels et matériels!



To ensure the optimal function of the panel, the touch screen should be cleaned in regular intervals!

To avoid damaging the touch screen, using either the fingers or a stylus to operate the panel is recommended.

## 11 Transport/Storage



This device contains sensitive electronics. During transport and storage, high mechanical stress must therefore be avoided.

For storage and transport, the same values for humidity and vibration as for operation must be maintained!

### CAUTION



Temperature and humidity fluctuations may occur during transport. Ensure that no moisture condenses in or on the device.

Pendant le transport, des fluctuations de température et d'humidité peuvent survenir. Veillez à ce qu'il n'y ait pas de condensation d'humidité dans ou sur l'appareil.

## 12 Assembly/Installation

### 12.1 Check List

#### 12.1.1 Check Contents of Delivery

Ensure that the contents of the delivery are complete and intact. See chapter 1.3 Contents of Delivery for more information.

**WARNING**

Do not use damaged components. These could disrupt or damage your system.

If damaged components are found in the delivery, please contact our customer service.

N'utilisez pas de composants endommagés. Cela pourrait perturber ou endommager votre système.

Si des composants endommagés se trouvent dans la livraison, veuillez contacter notre service clientèle.

### 12.2 Maintenance

This product was constructed for low-maintenance operation.

### 12.3 Repair



When sent for repair, the panel should be transported in the original packaging if possible. Otherwise, packaging should be selected that sufficiently protects the product from external mechanical influences. Such as cardboard filled with air cushioning.

In the event of a defect/repair, send the panel with a detailed error description to the address listed at the beginning of this document.

## 13 Disposal



When disposing of the panel, the national electronic scrap regulation must be observed.

The device must not be discarded with domestic waste.





## Documentation Changes

Change date	Affected page(s)	Chapter	Note
11.02.2019	16	8.2 CAN Bus Data Transfer Rate	Value 0 - Baud rate 615 kBaud/s removed